

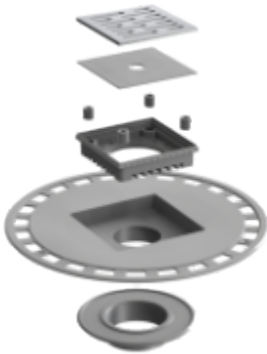

HYDRO BAN[®] Bonding Flange Drain

DS-36660.1-0226

**Globally Proven
Construction Solutions**



1. PRODUCT NAME

HYDRO BAN[®] Bonding Flange Drain

2. MANUFACTURER

LATICRETE International, Inc.
1 LATICRETE Park North
Bethany, CT 06524-3423 USA

Telephone: +1.203.393.0010, ext. 1235

Toll Free: 1.800.243.4788, ext. 1235

Fax: +1.203.393.1684

Website: laticrete.com

3. PRODUCT DESCRIPTION

HYDRO BAN Bonding Flange Drain and the HYDRO BAN Bonding Flange Tile Drain are low profile floor drains specifically designed for bonded waterproofing installations with HYDRO BAN waterproofing membrane. HYDRO BAN Bonding Flange Drains allow for the installation in a shower eliminating the pre-slope and primary shower pan liner according to TCNA Method B422.

Uses

- Interior applications only
- Showers
- Commercial and residential bathrooms and laundries
- Kitchens and food processing areas

Advantages

- Grates are 4"x4" (10 x 10 cm) to match most common tile sizes
- Attaches to 2" (50 mm), 3" (76 mm) and 3" (88 mm) waste lines

- Tile-in grate available to match floor tile
- Eliminates pre-slope and primary shower pan for a faster installation
- Made from heavy duty PVC or ABS and 304L stainless steel to provide long lasting performance
- HYDRO BAN waterproofing membranes bond directly to PVC or ABS flange
- Integrates seamlessly with portland cement mortar beds waterproofed with HYDRO BAN

Suitable Substrates (Interior Use Only)

- Concrete
- Exterior Glue Plywood
- Cement Mortar Bed
- Cement Backer Board

Packaging

The HYDRO BAN Bonding Flange Drain is a 2-piece drain flange, adjusting ring and a 4" x 4" (102 x 102 mm) grate assembly in variety of different finishes and styles. The HYDRO BAN Bonding Flange Tile Drain is a four-piece drain flange, adjusting ring and a 4" x 4" (102 x 102 mm) grate assembly that can be tiled to match the shower floor. All Bonding Flange Drains are available with either PVC or ABS Bonding Flange. When ordering a HYDRO BAN Bonding Flange Drain check with local code official to determine whether a PVC or ABS HYDRO BAN Bonding Flange Drain is required. Most areas in the United States will require a PVC drain connection except California and some surrounding states. Check local plumbing code for drain composition requirements.

Shelf Life

Two years unopened. Store at 40°F to 75°F (4°-24°C) in a covered area (out of the sun). Material should be kept in a cool dry place prior to application. Do not allow to freeze.

Limitations

- Adhesives/mastics, mortars and grouts for ceramic tile, pavers, brick and stone are not replacements for waterproofing membranes. When a waterproofing membrane is required, use a waterproofing membrane (see Section 10 FILING SYSTEMS).
- Note: Surfaces must be structurally sound, stable and rigid enough to support ceramic/stone tile, thin brick

and similar finishes. Substrate deflection under all live, dead and impact loads, including concentrated loads, must not exceed L/360 for thin bed ceramic tile/brick installations or L/480 for thin bed stone installations where L=span length.

Cautions

- Protect finished work from traffic until fully cured

4. TECHNICAL DATA

Applicable Standard

- Code approval per ASME .18 B125.2(US and Canada)

Working Properties

The HYDRO BAN Bonding Flange Drain and HYDRO BAN Bonding Flange Tile Drain series installs per TCNA B422 using HYDRO BAN as the waterproofing membrane.

Specifications subject to change without notification. Results shown are typical but reflect test procedures used. Actual field performance will depend on installation methods and site conditions.

5. INSTALLATION

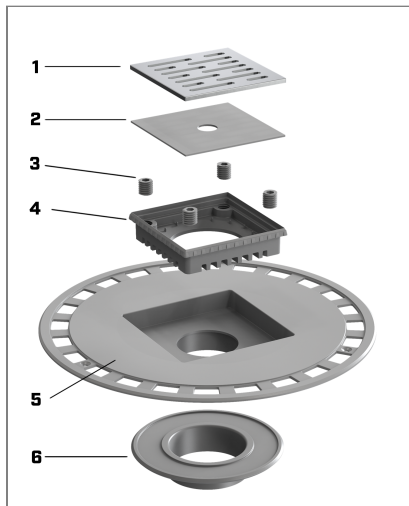

4 x 4 Metal Grate Assembly (FIG 1)

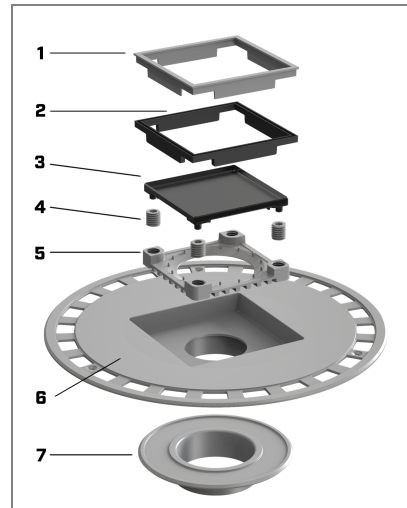

4 x 4 Tile-in Assembly (FIG 2)

Surface Preparation

All surfaces should be between 40°F (4°C) and 90°F (32°C) and structurally sound, clean and free of all dirt, oil, grease, laitance, paint, concrete sealers or curing compounds. Dry dusty concrete slabs or masonry should be dampened and excess water swept off. Installation may be made on a damp surface. Expansion joints shall be provided through the tile work from all construction or expansion joints in the substrate. Follow ANSI specification A108.01 – 3.7: Requirements for Movement Joints: Preparations by Other Trades” or TCNA detail EJ – 171 “Movement Joints – Vertical & Horizontal”. Do not cover expansion joints with mortar.

Bonded Mortar Bed—Installation (FIG 1 & 2)

Before placing mortar, apply a slurry bond coat made from 254 Platinum. While the slurry bond coat is wet, spread 3701 Fortified Mortar and compact well. Mortar beds shall be 3/4" (19 mm) minimum to 2" (50 mm) maximum. Mortar beds in excess of 2" (50 mm) thick shall be detailed by the architect per TCNA F112. Prior to installing the HYDRO BAN® Bonding Flange Drain (1) make sure the backer board has been installed on the walls following the manufacturer’s recommendations. The HYDRO BAN Bonding Flange Drain should be installed per TCNA Method B422. Before installing the HYDRO BAN Bonding Flange Drains make sure the opening in the floor where the waste line connection is made is 4-1/2" (114 mm) in diameter. The lip of the HYDRO BAN Bonding Flange Drain should sit approximately 1-1/4" (32 mm) above the substrate. Dry fit the HYDRO BAN Bonding Flange Drain through the hole and to the waste line below.

When connecting to a 2" (50 mm) waste line which is already in place the top of the waste line should be 1-3/4" (44 mm) below the surface of the substrate. Make sure that the HYDRO BAN Bonding Flange Drain is PVC when connecting to a PVC waste line or ABS when connecting to an ABS waste line. Cement the HYDRO BAN Bonding Flange Drain in place using PVC solvent and cement for PVC and ABS solvent and Cement for ABS HYDRO BAN Bonding Flange Drain and waste line connections. Make sure that the HYDRO BAN Bonding

Flange is level before the PVC or ABS cement has cured. DO NOT MIX materials, this will cause a failure in the pipe weld. When installed over EGP the bonding flange (1) Fig 1 and 2 can be screwed to the substrate using stainless steel or zinc coated 3" (76 mm) drywall screws. There are four countersunk holes around the perimeter of the bonding flange (1) for this purpose. The installation is now ready to accept the mortar bed.

Mortar Bed—Installation Over Concrete (see ES-B422BFD Concrete Bonded and ES-B422BFD Concrete Unbonded)

For a bonded mortar bed over concrete installation, before placing mortar, apply a slurry bond coat made from 254 Platinum. While the slurry bond coat is wet, spread 3701 Fortified Mortar Bed and compact well. Bonded mortar beds over concrete shall be 3/4" (19 mm) minimum to 2" (50 mm) maximum.

For an unbonded installation over concrete (see ES-415BFD Concrete Unbonded) a cleavage membrane as specified in ANSI A108.02-3.8 should be used in place of the slurry bond coat. When using the unbonded method, install the cleavage membrane prior to the HYDRO BAN Bonding Flange Drain installation. The 3701 Fortified Mortar should be reinforced with 2" x 2" (50 x 50 mm) reinforcing mesh. Unbonded mortar beds over concrete shall be 1-1/4" (32 mm) minimum to 2" (50 mm) maximum.

In both bonded and unbonded mortar bed installations place enough 3701 Fortified Mortar Bed under the HYDRO BAN Bonding Flange Drain to support the flange of the drain. Minimum height from the flange to the substrate should be 1-1/4" (32 mm). Next place a ribbon of 3701 Fortified Mortar Bed along the opposite walls to create a 1/4" (6 mm) per foot slope to the HYDRO BAN Bonding Flange Drain. Fill the area between the drain and the walls with 3701 Fortified Mortar Bed; screed and compact well. Mortar beds in excess of 2" (50 mm) thick shall be detailed by the architect per TCNA F112.

Mortar Bed – Installation Over EGP (see ES-422BFD EGP Bonded and ES-422BFD EGP Unbonded)

For a bonded mortar bed over EGP installation, before placing mortar, install a cleavage membrane as specified in ANSI A108.02-3.8, expanded metal lath (minimum 2.5 pounds (1.1 kg)/square yard [0.84 square meters]) is then nailed or stapled to the subfloor over the cleavage membrane. The cleavage membrane and lath should be installed prior to the bonding flange (1) installation. Following the lath installation spread 3701 Fortified Mortar and compact well. Bonded mortar beds over EGP shall be 3/4" (19 mm) minimum to 1 1/2" (38 mm) maximum.

For an unbonded installation over EGP (see ES-422BFD EGP Unbonded) install a cleavage membrane as specified in ANSI A108.02-3.8 prior to the HYDRO BAN Bonding Flange Drain installation. For an unbonded mortar bed the 3701 Fortified Mortar Bed should be reinforced with 2" x 2" (50 x 50 mm) reinforcing mesh. In both bonded and unbonded mortar bed installations place enough 3701 Fortified Mortar Bed where the HYDRO BAN Bonding Flange Drain will be set to

support under the flange of the drain. Minimum height from the flange to the substrate should be 1-1/4" (32 mm). Next place a ribbon of 3701 Fortified Mortar Bed along the opposite wall to create a 1/4" (6 mm) per foot slope to the HYDRO BAN Bonding Flange Drain. Fill the area between the drain and the walls with 3701 Fortified Mortar Bed; screed and compact well. Mortar beds in excess of 2" (50 mm) thick shall be detailed by the architect per TCNA F112-11.

Bonding Flange Drain with 4x4 grate (FIG 2):

After the bonding flange has been connected to the domestic waste line, fit the Adjusting Base (4), Height Adjusting Screws (3), in the square cut out of the Bonding Flange Assembly (5), Only use the Clamping Ring Adapter (6) if needed.

The Mortar Cap (2), can also be inserted at this time to help ensure no unneeded material falls into the waste outlet.

Please note the Height Adjusting Screws (3) are to be inserted into the Adjusting Base (4), prior to the combination being inserted into the Bonding Flange Assembly (5).

The Bonding Flange Assembly (5) features additional room for play and lining up to the floor tile, once you position has been selected and your height has been adjusting, using the Height Adjusting Screws (3), thinset is applied to the bottom the Adjusting Base (4) and the Bonding Flange Assembly (5). After final position is set, additional thinset should be used to fill in any gaps. Use the border of the Adjusting Base (4), as the stopping point when tiling out to the walls and perimeter of the shower. Once the complete wall and floor tiling is complete, the Mortar Cap (2) can be removed, and the 4x4 Grate (1) can be snapped into place A bead of LATICRETE should then be added around the perimeter for finishing.

Bonding Flange Drain with a tile-in grate (FIG 2):

After the bonding flange has been connected to the domestic waste line, fit the Adjusting Base (5), Height Adjusting Screws (4), Stiffener Support (1), Stiffener Gasket (2) and in the square cut out of the Bonding Flange Assembly (6), Only use the Clamping Ring Adapter (7) if needed.

Please note the Stiffener Support (1) is to be inserted in the Stiffener Gasket (2) prior to placing it in the Bonding Flange Assembly (6), the Height Adjusting Screws (4) are to be inserted into the Adjusting Base (5), and the feet of the Tile-in Plate (3) are placed into the opening in the top of the screws.

The Bonding Flange Assembly (6) features additional room for play and lining up to the floor tile, once you position has been selected and your height has been adjusting, using the Height Adjusting Screws (4), thinset is applied to the bottom the Adjusting Base (5) and the Bonding Flange Assembly (6). After final position is set, additional thinset should be used to fill in any gaps. Use the border of the Stiffener Gasket (2) as the stopping point when tiling out to the walls and perimeter of the shower. Once the wall and floor tiling is complete, remove Stiffener Support (1), Stiffener Gasket (2). You then applied thin-set to Tile-in Plate (3) and back-butter

the final tile. Then adhere with pressure the final tile to Tile-in Plate (3). Then you place the combination back onto Adjusting Base (5), in the screws and place that into the Bonding Flange Assembly (6).

For enhanced adhesion you can also add one coat of HYDRO BAN liquid to Tile-in Plate (3) prior to (and letting cure) the back-buttering process.

WATERPROOFING W/ HYDRO BAN and Tile (Fig. 1 and Fig. 2)

1. Before applying HYDRO BAN make sure the bonding flange is clean and free of any mortar, thin-set, grease, dirt or finger prints that could cause debonding of the HYDRO BAN. Apply HYDRO BAN waterproofing membrane according to DS 663.0 and 663.5. Cover wall and mortar with two coats of HYDRO BAN. Apply two coats of waterproofing on top of the flange from the first vertical radius and onto the 3701 Fortified Mortar. Alternatively Waterproofing/Anti-Fracture Fabric can be imbedded into the HYDRO BAN around the bonding flange overlapping the flange and the 3701 Fortified Mortar Bed. **DO NOT** waterproof the inside flange walls and bottom after the first vertical radius.
2. When the second coat of HYDRO BAN is dry, tile can be installed using a polymer fortified thin-set and grouted with PERMACOLOR[®] Select, PERMACOLOR Grout or SPECTRALOCK[®] PRO Premium Grout[†].
3. Tile walls and floors; when thin-set and tile are ready to be installed around the HYDRO BAN Bonding Flange Drain comb thin-set onto bonding flange (D) and set top plate (C) onto the bonding flange. Thin-set should ooze through the triangle voids in the top plate (C). Scrape any excess thin-set from the top plate (C) using a trowel. As you tile closer to the top plate insert the threaded outlet of the top and bottom frame (A and B) into the top plate (C). Adjust the top and bottom frame by screwing in the threaded outlet to the top plate (C) to allow for height adjustment (fig. 2). Thin-set over the top plate (C) and install tile.
4. If using the tile-in grate with the HYDRO BAN Bonding Flange Drain, remove top frame (A) and prime surface with two coats of HYDRO BAN prior to installing tile within the frame using a polymer fortified thin-set. Make sure that the stainless steel top frame (A) is free of grease, dirt or finger prints prior to applying the HYDRO BAN.
5. The finished floor must be 1/16" (1.5 mm) higher than the top and bottom frame (A and B with tile).

Cleaning

Clean tools and tile work with water while the 3701 Fortified Mortar and HYDRO BAN are fresh. NEVER use steel wool, wire brushes, chlorine bleach, hydrochloric acid (muriatic acid), or any chloride cleaners on stainless steel. Instead clean the polished and brushed stainless steel grates with commonly available products such as Bar Keepers Friend[®] or Soft Scrub[®]. Aside from the Brushed and Polished Stainless Grate grates, all other finishes should only be cleaned with soap and warm water and light brushing with a soft bristle brush.

6. AVAILABILITY AND COST

Availability

LATICRETE materials are available worldwide.

For Distributor Information, Call:

Toll Free: 1.800.243.4788

Telephone: +1.203.393.0010

For on-line distributor information, visit LATICRETE at laticrete.com

Cost

Contact a LATICRETE Distributor in your area.

7. WARRANTY

See 10. FILING SYSTEM:

- 1 Year Product Warranty (US) (English)
- 10 Year System Warranty (US) (English)
- 25 Year System Warranty (US) (English)
- Lifetime System Warranty (US) (English)

8. MAINTENANCE

The non-finish or non-exposed portion of the LATICRETE Hydro Ban Shower System products require no maintenance. However, installation performance and durability may depend on properly maintaining products and finishes that cover the LATICRETE Hydro Ban Shower System products and those supplied by other manufacturers. The exposed portion of the stainless steel LATICRETE Hydro Ban Drains can be cleaned and maintained using a non-abrasive stainless steel cleaner or polish with a clean soft white cotton cloth. When cleaning the oil rubbed bronze drains use a non-abrasive cleaner and clean soft cloth. When cleaning the stainless steel or oil rubbed bronze drains contact the cleaner manufacturer if another cleaner type will be used to ensure compatibility with the drain material.

9. TECHNICAL SERVICES

Technical Assistance

Information is available by calling the LATICRETE Technical Service Hotline:

Toll Free: 1.800.243.4788, ext. 1235

Telephone: +1.203.393.0010, ext. 1235

Fax: +1.203.393.1948

Technical and Safety Literature

To acquire technical and safety literature, please visit our website at laticrete.com.

10. FILING SYSTEM

Additional product information is available on our website at laticrete.com. The following is a list of related documents:

- DS 230.13: LATICRETE Product Warranty
- DS 230.10: LATICRETE 10 Year System Warranty
- DS 025.0: LATICRETE 25 Year System Warranty
- DS 230.99: LATICRETE Lifetime System Warranty

- DS 100.0: 3701 Fortified Mortar
- DS 250.0: PERMACOLOR®
- DS 281.0: PERMACOLOR Select
- DS 663.0: HYDRO BAN®
- DS 677.0: 254 Platinum
- DS 681.0: SPECTRALOCK® PRO Premium Grout†
- DS 663.5: HYDRO BAN to

LATICRETE International, Inc.

One LATICRETE Park North, Bethany, CT 06524-3423 USA • 1.800.243.4788 • +1.203.393.0010 • www.laticrete.com

© 2026 LATICRETE International, Inc. All trademarks shown are the intellectual properties of their respective owners.